



SONIMAT

Europe Technologies group

Cutting and Welding Solutions



Cutting and welding solutions for industry

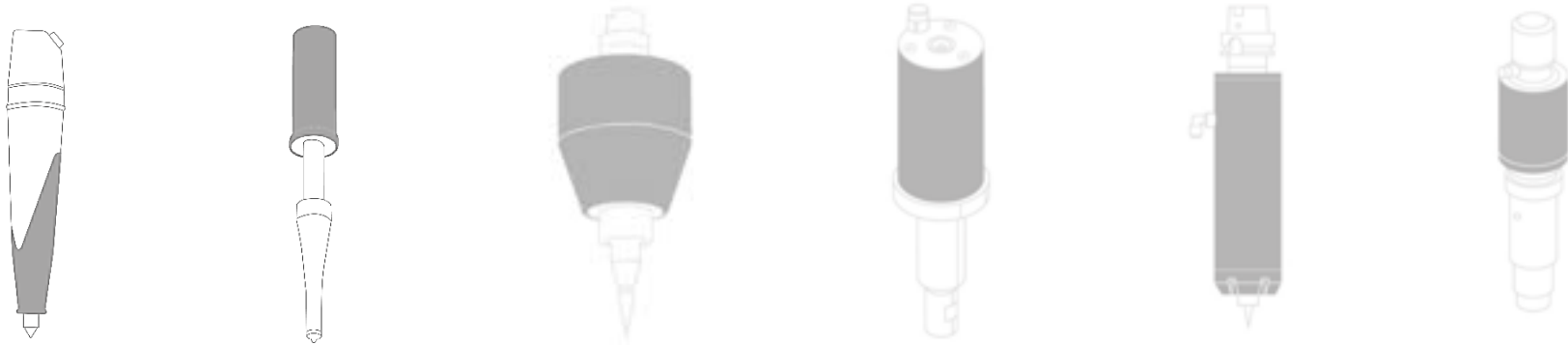

Portative and automated solutions for ultrasonic cutting and welding of composites materials

Summary



- Ultrasonic cutting solutions.....4
 - Ultrasonic cutting portable solution8
 - Ultrasonic cutting and surfacing end-effector.....13

- Composite welding solutions.....33
 - Ultrasonic portative welding solution.....35
 - Standard machine for ultrasonic welding.....38
 - Customized machine for ultrasonic welding.....40

- Customized machines for composites welding and cutting.....42
 - Spin welding.....43
 - Hot plate welding.....45
 - Infrared welding.....46
 - Laser welding.....48

ULTRASONIC CUTTING SOLUTIONS

©All rights reserved to Multiax - 2019



Ultrasonic Technology

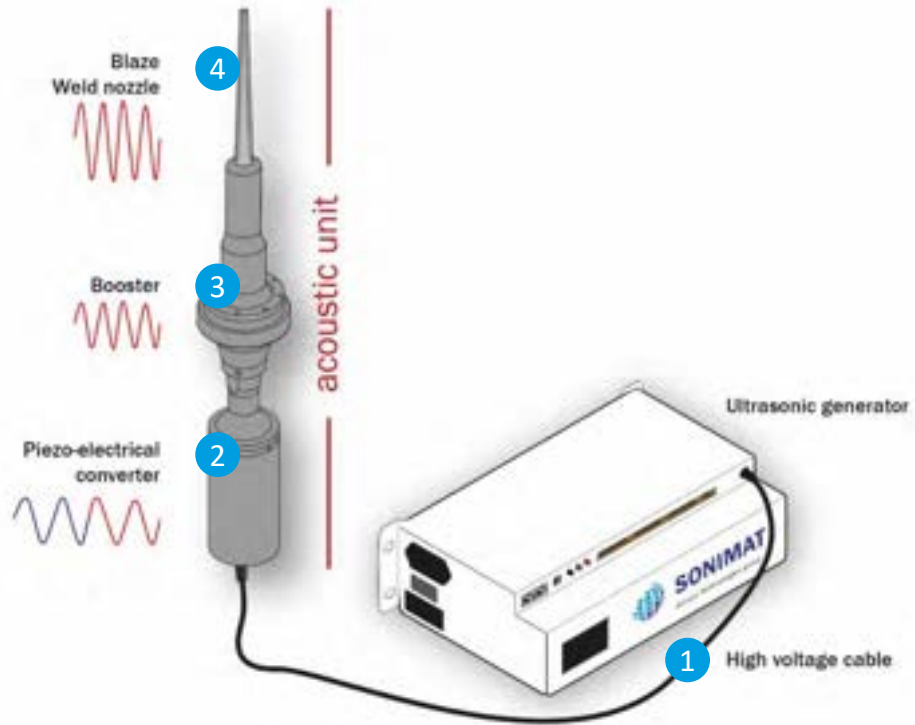

- 1 Ultrasonic emission
- 2 Electrical signal converted into mechanical energy
- 3 Increase of the vibration amplitude through the booster
- 4 Tool vibration for cutting and welding (20Khz to 40Khz)

A solution for each application

1

Portative Equipment



2

End-effectors
embeddable on
machines



3

Customized machines
dedicated to customer's
need



Ultrasonic cutting solutions | *Technology advantages*

Increasing productivity

- Reduced cutting effort
- Reduced maintenance
- Cutting velocity increased
- Cutting until 125mm thickness
- Continuous work
- Extended blade life cycle
- No grip on tool
- Embeddable solutions
- Easy handling and set-up

Improving cutting quality

- No thermal degradation
- No fraying
- No dust

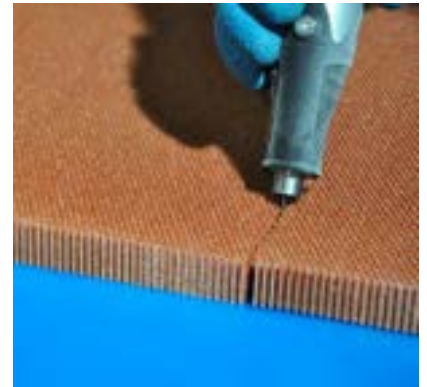
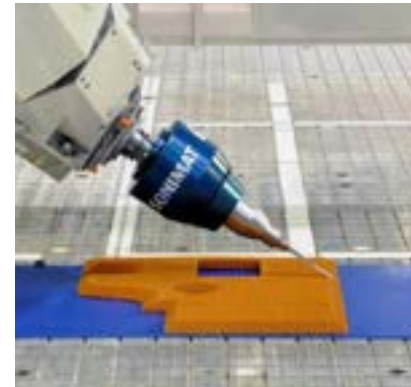



ULTRASONIC CUTTING PORTABLE SOLUTION



SSP-Portative equipment for ultrasonic cutting

> FEATURES

- Ultrasonic generator
- Easy way to replace blades
- Lengths of ultrasonic cable: 3, 5 or 10m
- Frequency between 20kHz to 40kHz depending of cutting or welding application

> RAW MATERIALS

- **Honeycomb:** NOMEX, Aluminium, foam
- **Composites:** carbon, aramid, glass (dry fiber and pre-impregnated)
- **Other materials:** elastomer, cardboard, insulating materials



NB: Ultrasonic welding is possible by simply changing the handle

SSP-Portative equipment for ultrasonic cutting | *Blades range*



Depending of the blade's length, two different handles are available

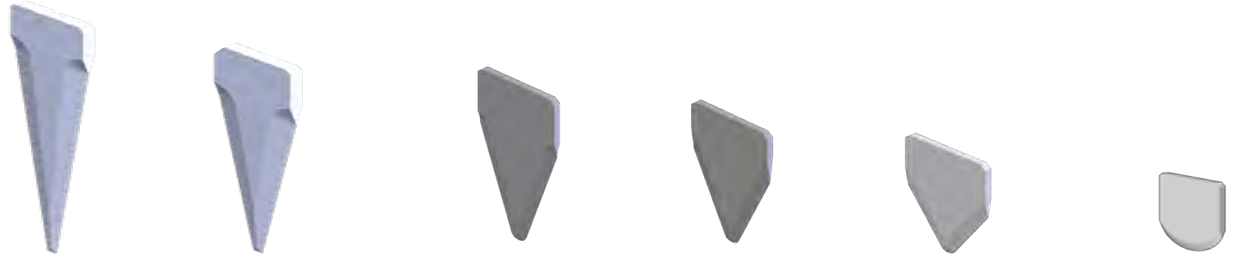

35mm

25mm

15mm

10mm

8mm

Single layer
4mm

Large blade handle

Small blade handle

Ultrasonic cutting - portable solution | *fibers applications*

➤ Dry fibers application



- Blade: single layer

➤ Thermoplastic carbon fiber



- Blade: 8mm

Ultrasonic cutting - portable solution | *Honeycomb applications*

> Honeycomb NOMEX



- Blade: 25mm
- Material thickness: 20mm

> Honeycomb Aluminum



- Blade: 35mm
- Material thickness: 20mm



ULTRASONIC CUTTING END-EFFECTORS



Ultrasonic cutting End-Effectors | *Range of products*



SONIBLADE L

- CNC machines/robots
- Honeycomb cutting and surface machining
- Thickness up to 125 mm

SONIBLADE M

- CNC machines/robots
- Composites cutting
- Thickness up to 35 mm



SONIBLADE S

- ATL/AFP machines and Robots
- Composites cutting
- Thickness up to 2mm

SONIBLADE T

- XY cutting tables
- Composites/ Elastomer cutting
- Thickness up to 15mm



> FEATURES

- **End-Effector adjustable** for each type of robots/CNC machines
- **Ultrasonic generator: 20KHz**
- **Automated Cooling** of the ultrasonic components
- No integrity risk to the machining spindle
- Effector can be fitted with a cutting blade or a rotating surfacing disc

> RAW MATERIALS

- **Honeycomb:** NOMEX, Aluminium, foam
- **Composites:** carbon, aramid, glass (dry fiber and pre-impregnated)
- **Other materials:** elastomer, cardboard, insulating materials



**Attachment HSK
MORSE or BT**
Comutable cones
depending on
customer request

Slip ring:
Up to 3000 RPM

Easy mounting of
the blade or disc



Length:
375mm

SONIBLADE L | *Ultrasonic & Pneumatic connections*

Manual Connection

Needing a plate in order to avoid the rotation
Manual clamping of ultrasonic and pneumatic cables

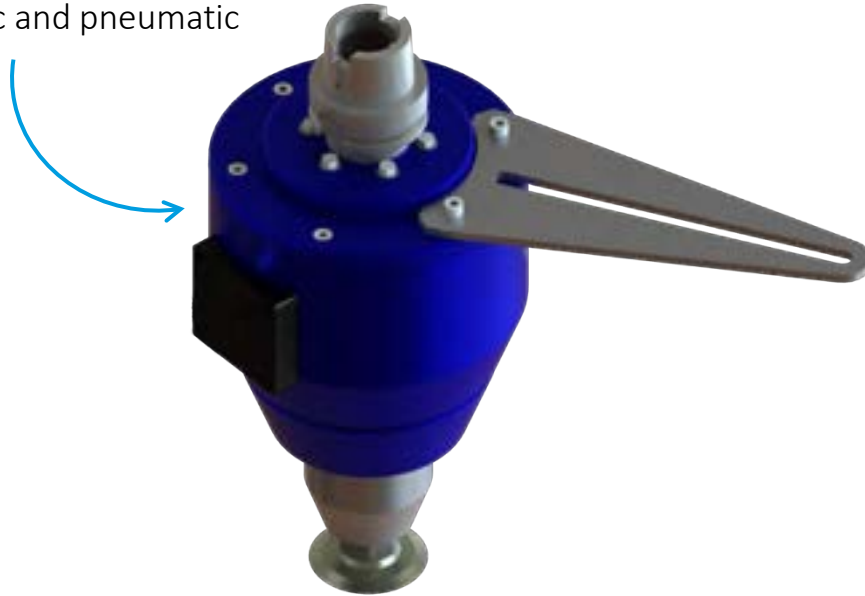

Automated Connection

Allowing the customer to automatically connect ultrasonic and pneumatic cables and adjust ultrasonic parameters by encoding



Communication with the Ultrasonic Generator

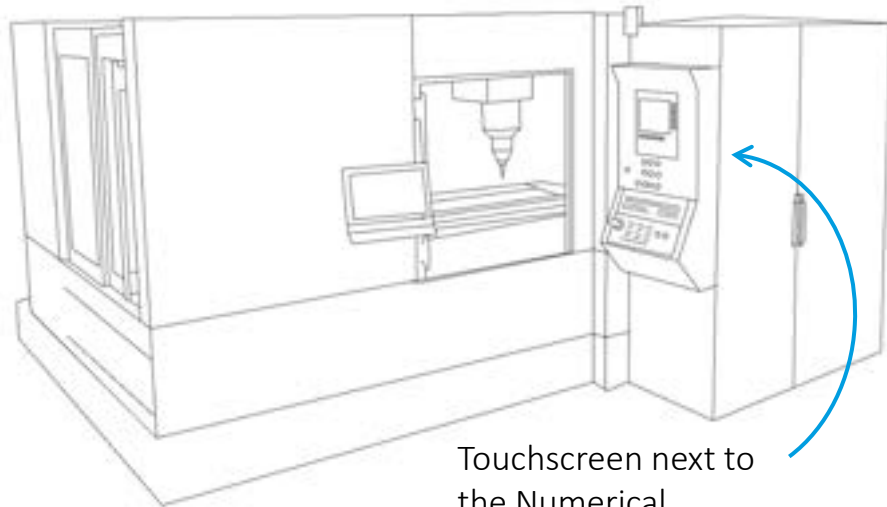

Touchscreen next to the Numerical Controller of the machine

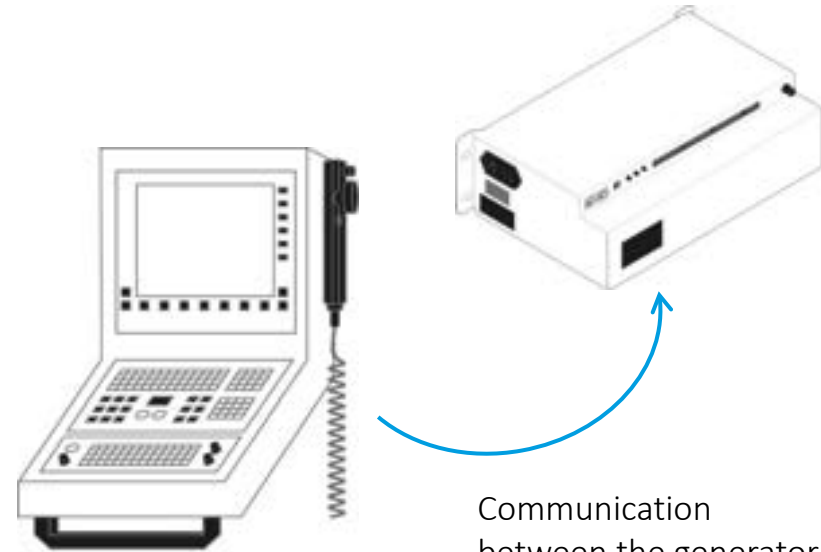

Communication between the generator and the Numerical Controller

NB: this option is also valid for our entire SONIBLADE range

SONIBLADE L | *Blades range*



125mm 80mm 78mm 50mm 40mm 30mm

Customized blade can be developed for your specific needs

SONIBLADE L | Discs range



Disc



Ø63mm Ø50mm Ø18,3mm

Extended disc

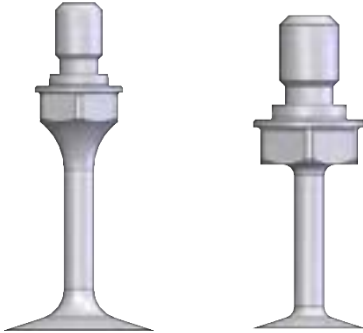

Ø25mm Ø15mm

Customized disc can be developed for your specific needs

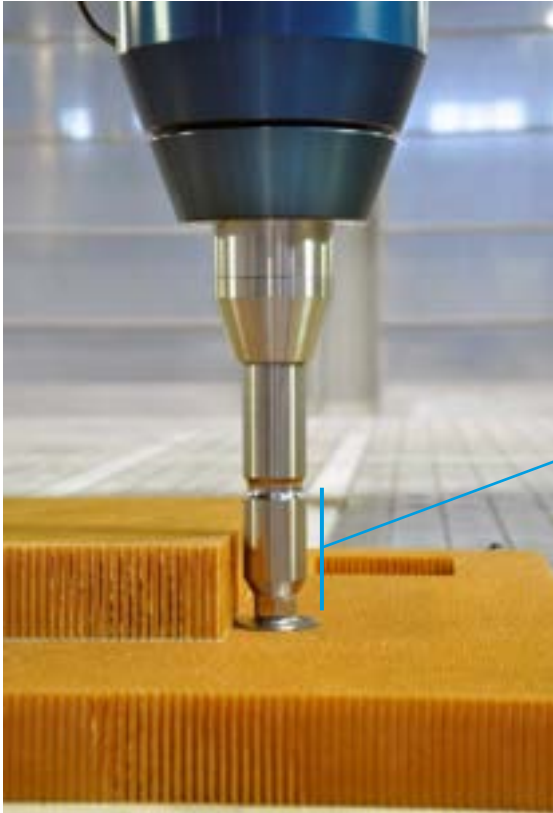

Option

Longer sonotrode for surface machining

- Increasing the length of the sonotrode by 125mm
- **Objective:** to be able to access complex geometrical areas (curved and layered parts...)

Available for the SONIBLADE L disc and blade range

SONIBLADE L | *Robot applications*

> Honeycomb NOMEX

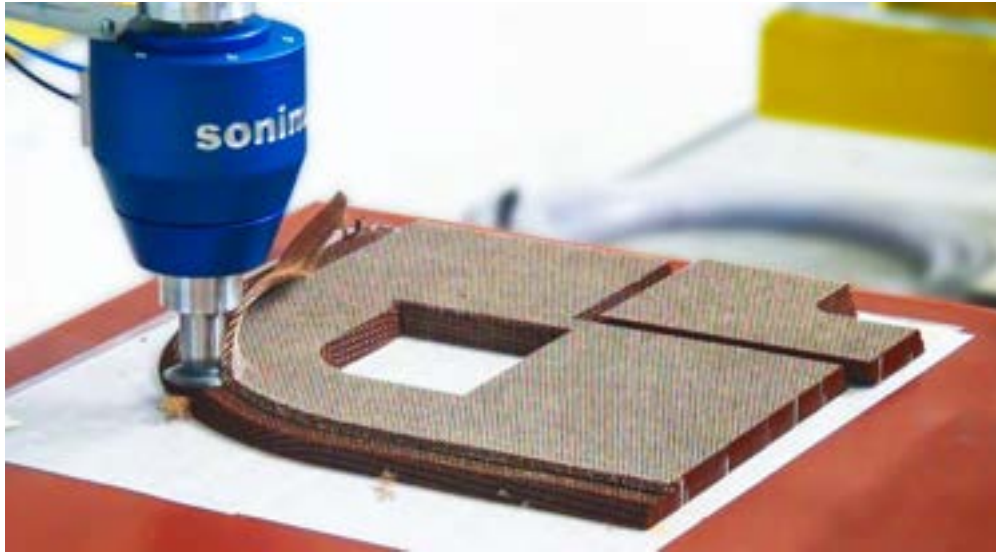

- Disc: \varnothing 63mm
- Material thickness: 30mm

> Honeycomb Aluminum

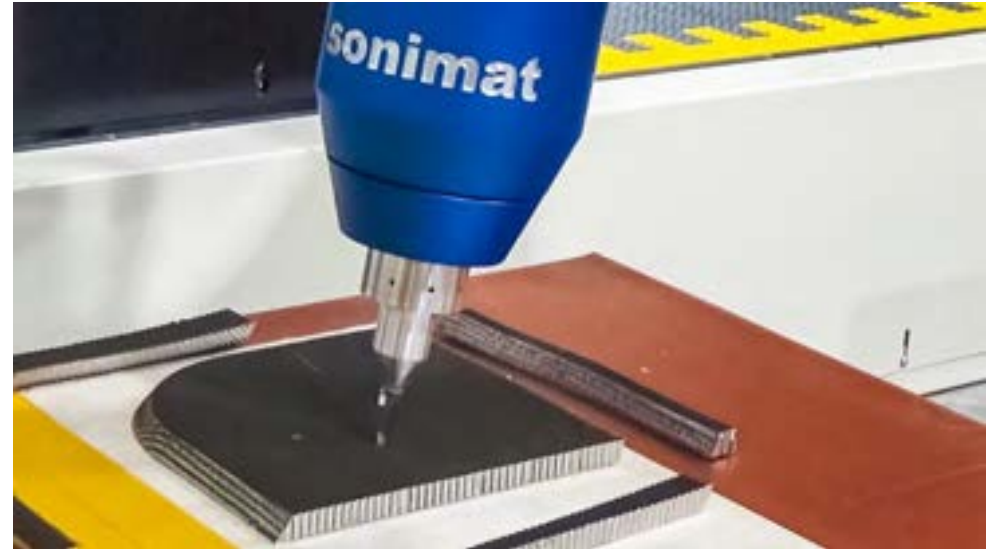

- Blade: 50mm
- Material thickness: 30mm

SONIBLADE L | *CNC applications*

> NOMEX Honeycomb



- Blade: 50mm

> NOMEX Honeycomb



- Blade: 125mm
- Material thickness: 70mm

> FEATURES

- **End-Effector adjustable** for each type of robots and machines
- **Cutting speed** up to 150m/min
- **Ultrasonic generator** : 20KHz
- **Automated Cooling** of ultrasonic components
- Possibility of integrating automatic connection
- Possibility of integrating mechanical clamping for the robot

> RAW MATERIALS

- **Honeycomb**: NOMEX, Aramid, Aluminium, Foam
- **Composites**: Carbon, Aramid, Glass (dry fibre and pre-impregnated)
- **Other materials**: Elastomer, Cardboard, Insulation material, Fabrics, Leather



Attachment
Comutable cones depending on customer request

Indexed blades
Always mounted in the same position



Length:
348mm

Rotating collector



Avoiding cable's distortion

Automated Connection



Allowing the customer to automatically connect ultrasonic and pneumatic cables

Manual Connection



SONIBLADE M | *Blades range*

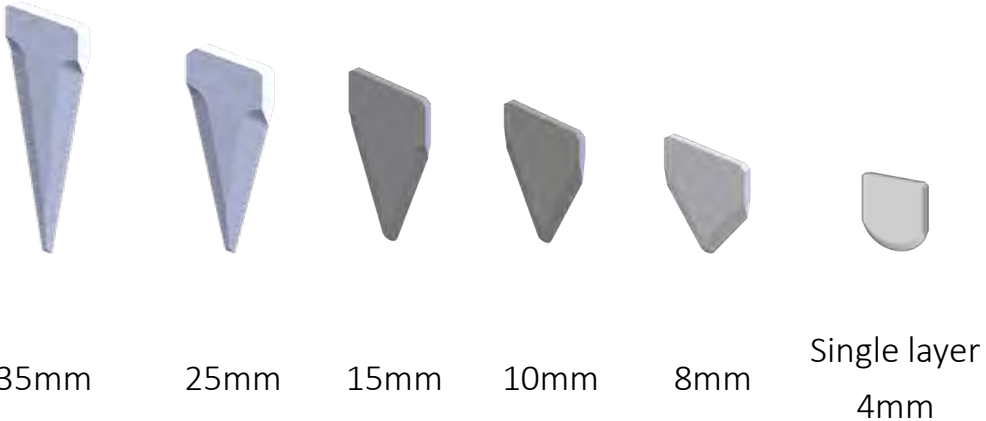

Customized blade can be developed for your specific needs

SONIBLADE M | *Applications*

- Set up of a SONIBLADE M effector on a 5-axis CNC machine



- Cutting of preformed carbon prepreg - 4mm thickness



SONIBLADE T | *XY Cutting Tables*

> FEATURES

- **Ultrasonic generator:** 30KHz
- Up to 15m of ultrasonic coaxial wire
- **Automated Cooling** of the ultrasonic components
- **Cutting speed** up to 110 m/min

> RAW MATERIALS

- **Honeycomb:** NOMEX, Aramid, Aluminium, Foam
- **Composites:** Carbon, Aramid, Glass (dry fibre and pre-impregnated)
- **Other materials:** Elastomer, Cardboard, Insulation material, Fabrics, Leather

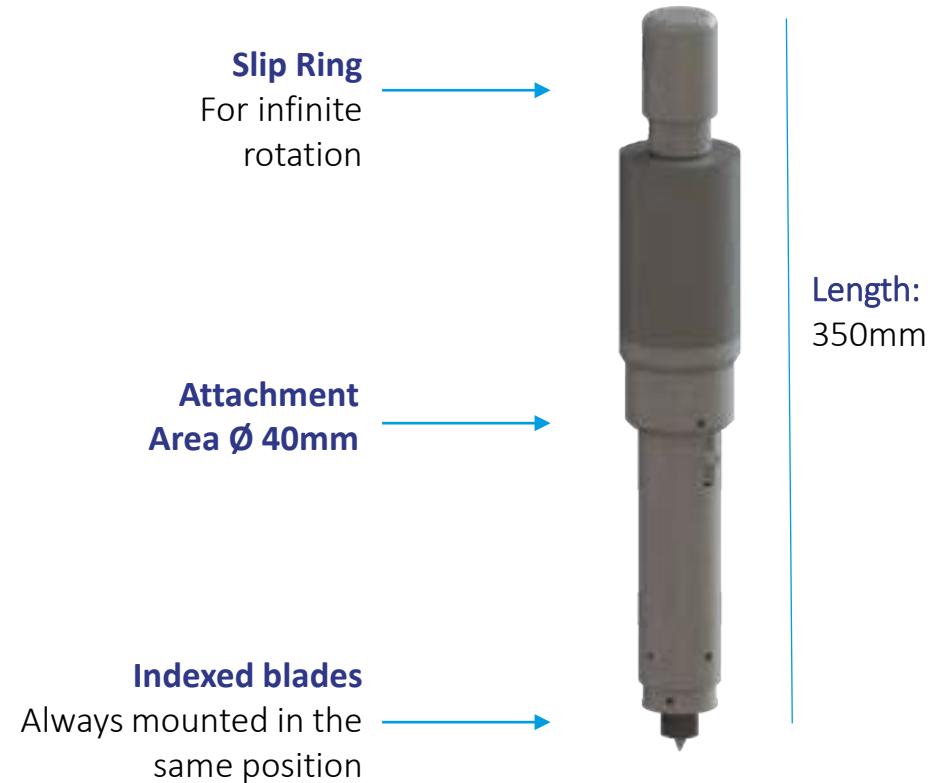

SONIBLADE T | *Blades range*



15mm



10mm



8mm



Single layer
4mm

Customized blade can be developed for your specific needs

SONIBLADE T | *Table applications*

➤ Glass Fiber – 8 layers – 50m/min – 30 kHz

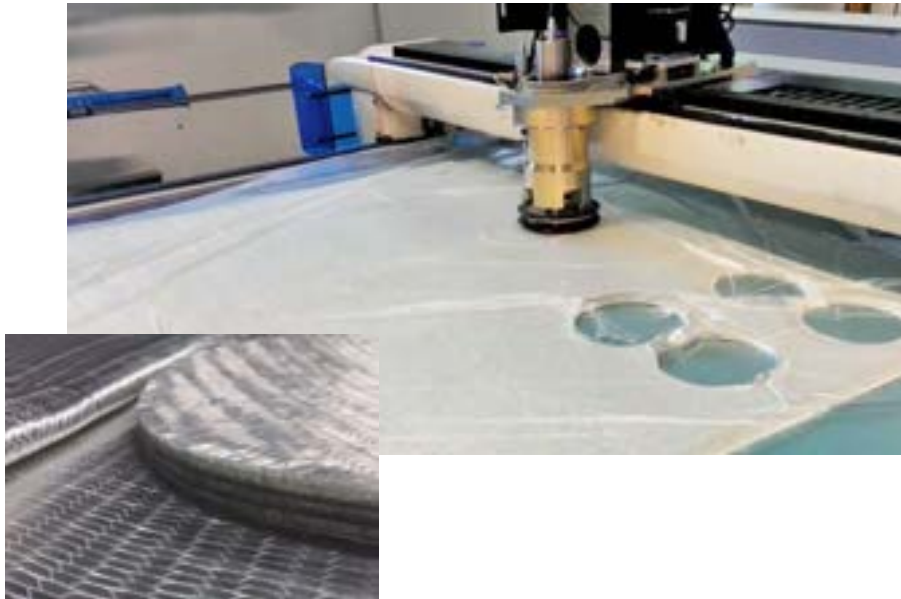

➤ Carbon Fiber – 1 layer 50m/min – 30 kHz

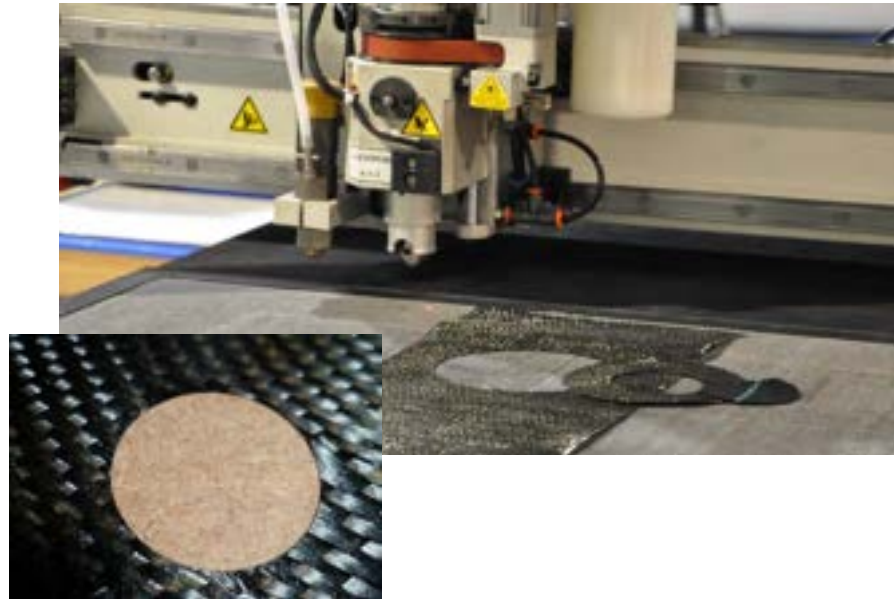

> FEATURES

- **Ultrasonic generator:** 40KHz
- Up to 15m of ultrasonic coaxial wire
- **Automated Cooling** of the ultrasonic components
- Maximum cutting thickness: 2mm
- Small effector size, easily integrated on the machine

The most compact ultrasonic device on the market

> RAW MATERIALS

- **Composites:** carbon, aramid (dry and pre-impregnated fiber)

Mechanical clamping area:
machine/effector interface

Indexed blades
Always mounted in the same position

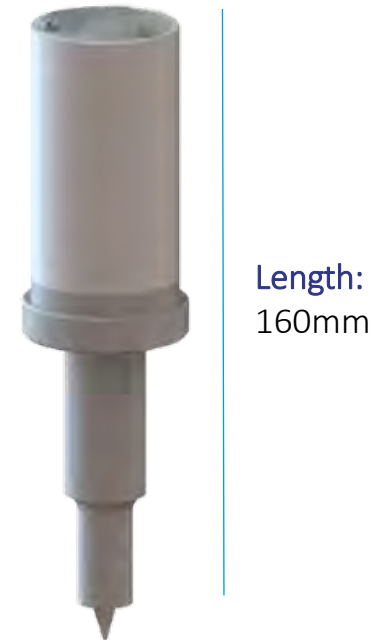

SONIBLADE S | *Blades range*

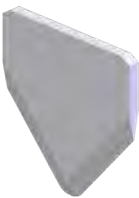

8mm



Single layer
4mm

Customized blade can be developed for your specific needs

 Integration of a SONIBLADE S effector

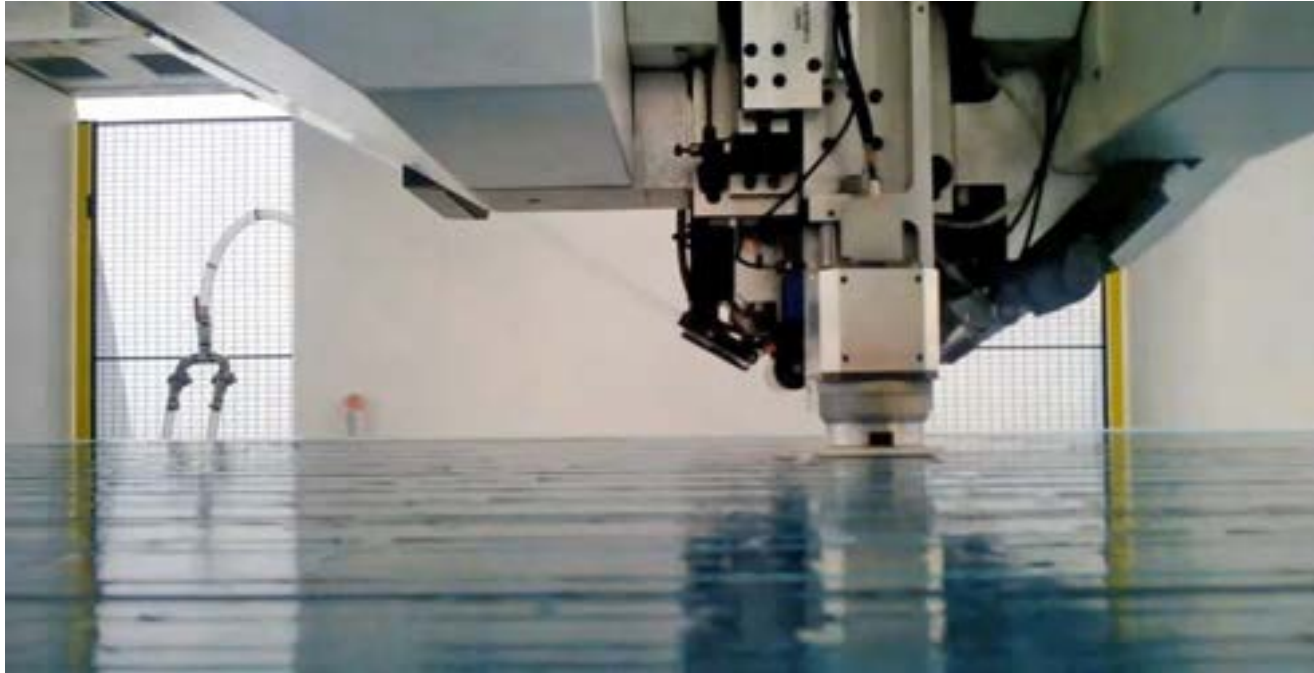



COMPOSITE WELDING SOLUTIONS



A solution for each application

1

Portative Equipment



2

Standard equipment
Press ESW



3

Customized machines
dedicated to customer's
needs



SSP-Portative equipment for ultrasonic welding

> FEATURES

- Ultrasonic generator
- 3/5m ultrasonic coaxial wire
- **Automatic frequency** (\simeq 20 up to 40KHz)
- Management of the welding time by the generator
- Dedicated to spot welding

> RAW MATERIALS

- Thermoplastic composite:
 - Pre-impregnated fabrics: powders, films, co-blends,
 - Composite plates, strips etc.
 - Resins: PA, PEI, PEEK, PEKK, PPS, etc.

Titanium horn



Commutable nozzles

Welding cycle management

- Transferred energy management
- Welding time management
- Range tuning

NB: handle is adaptable on the SSP-cutting

SSP-Portative equipment for ultrasonic welding | Nozzles



Commutable nozzles



Staking nozzle



Conical nozzle (F1)



Radial nozzle (F2)



Nozzle with steps (A1)



Nozzle with steps (A2)



Flat nozzle (B)



Diamond dots nozzle 1.0mm (B1)



Diamond dots nozzle 1.0mm (B2)

Portable ultrasonic welding | *Applications*

- Welding of consolidated layer in PA glass wire

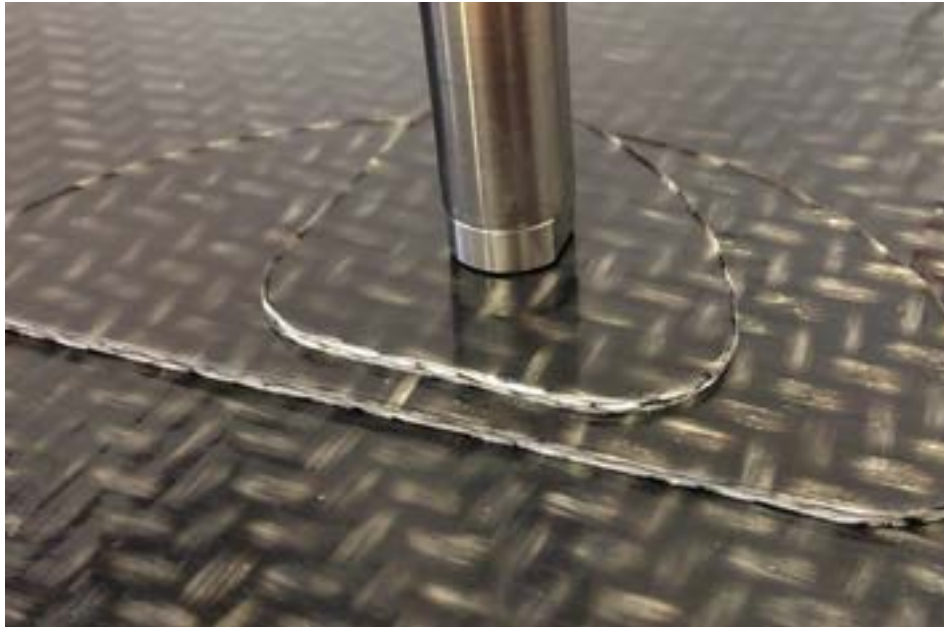

- Ultrasonic prepositioning of TP carbon peek layer



Ultrasonic Welding Solution | ESW



MACHINE FEATURES

- Two-handed control for operator safety
- Rapid change of the resonance stack
- Interchangeable and upgradable ultrasonic generator
- Strong structure rigidity
- Tripod tuning of the flatness
- Multiples configurations



COLORED TOUCH SCREEN INTERFACE FEATURES

- User-friendly programming
- Operating modes : constant speed or stress
- Welding stop : stop time, energy

OPTIONS

Rotating tray, Soundproof workstation,
Multi-head and Film unwinder system



ESW press



ESW press with frame

Ultrasonic Welding Solution | *Technology advantages*



High frequency vibrations are provided to the part in contact with the sonotrode. The heat generated at the interface of the two parts creates the weld.

> APPLICATIONS

Thermoplastic welding for small and medium parts

- Amorphous thermoplastic
- Thermoformed part

> ADVANTAGES

- **Excellent repeatability:** +/- 0,02mm
- **Quick welding:** inferior to 1 sec
- Without extra material recovery
- **Traceability:** Production data recording
- **High precision**

Materials the most commonly used: ABS, ABS-PC , PC, PA6, PA66, PMMA, PP, PS, PEEK, PEKK, HELIUM

THINK CUSTOMIZED !

We have been recognized for more than 25 years for our welding, cutting and composite materials processing solutions. Proud of this recognition, we also offer our customers the design and manufacture of customized machines with our cutting and welding processes: **ultrasonic cutting and welding / laser - infrared - spin welding – hot plate.**



ADVANTAGES:

- Proven and reliable cutting and welding processes
- Turnkey customized solutions
- The right answer to high speed rates and/or process repeatability
- Possible robotics integration
- Commissioning, training, technical assistance and maintenance by our teams

CUSTOMIZED MACHINES | for composite cutting & welding

- Customized machine for cutting thermoset composites



- Customized machine for welding of thermoplastic composites



A photograph of an industrial robotic welding cell. A robotic arm with a grey protective sleeve is positioned above a worktable. The worktable has a blue protective mat. The machine is white and grey, with various cables and components visible. The text "WELDING SOLUTIONS" is overlaid in white on the image.

WELDING SOLUTIONS



Spin Welding

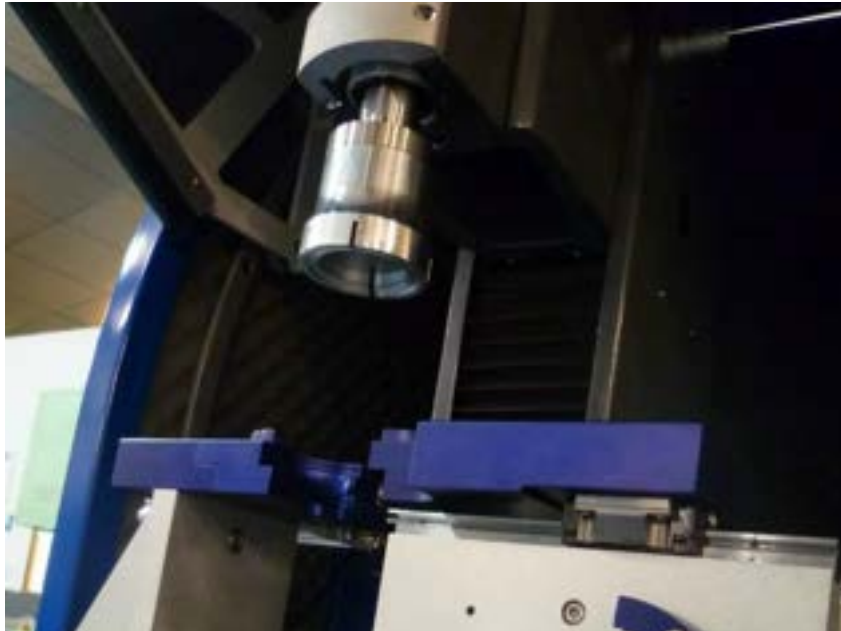

The welding is made by rotating the upper part of the assembly, and simultaneously applying a compressive force.

APPLICATIONS

Thermoplastic welding for small and medium revolution parts
(Ex: air system, vase, jar)

ADVANTAGES

Quality

- Excellent repeatability
- High precision / High linearity of the pressure
- Waterproof
- Strong mechanical resistance

Productivity

- Few influence of external parameters

Materials the most commonly used: POM, PPA PE, PP, PS, PBT, ABS, PA66, PA6, PEEK...

Design, manufacturing and control in our workshop



MACHINE FEATURES

- Opened frame for small and wide parts
- Column available alone
- High mechanical accuracy +/-0,02mm
- **Mobile protection door**
- **Integrated tooling management**



INTERFACE FEATURES

- User-friendly programming
- Welding curves display
- Recording of all data production



Hot plate Welding



The upper and lower sides of the part are pushed towards the hot plate in order to transfer the heat energy, then separated and compressed for assembly.

> APPLICATIONS

Thermoplastics welding for large parts with complex shape, smooth material and technical assembly

(Ex: waterproof part, Dashboard, Electronic control unit...)

> ADVANTAGES

Process

- Process traceability and repeatability
- Automatic recognition of tooling
- Optimized time control for weld line
- Forces, speed and position controls

Product

- Aesthetic
- Strong mechanical resistance
- Waterproof
- High linearity of the pressure

Materials the most commonly used : PE, POM, PP

Infrared Welding



The upper and lower sides of the part are pushed closed to the hot plate in order to transfer the heat energy, then removed and compressed for assembly.

> APPLICATIONS

Thermoplastics welding for large parts with complex shape (2D/3D), smooth material and technical assembly
(Ex: full beam, tank, filter, hose...)

> ADVANTAGES

Process

- Weld without blade fouling
- No color alteration
- Low energy consumption

Product

- Aesthetic
- Strong mechanical resistance
- Waterproof
- High linearity of the pressure

Materials the most commonly used : Tous PA, PBT, PPA, PPS, PP, PET PEEK



MACHINE FEATURES

- SONIMAT's hook mode
- Electrically driven press ramp up
- Operator safety with light curtain
- Automated recognition of the toolings



PROCESS FEATURES

- Traceability
- Repeatability
- Auto-tuning warning (control of coordination)
- Forces, speed and positions control



Laser Welding

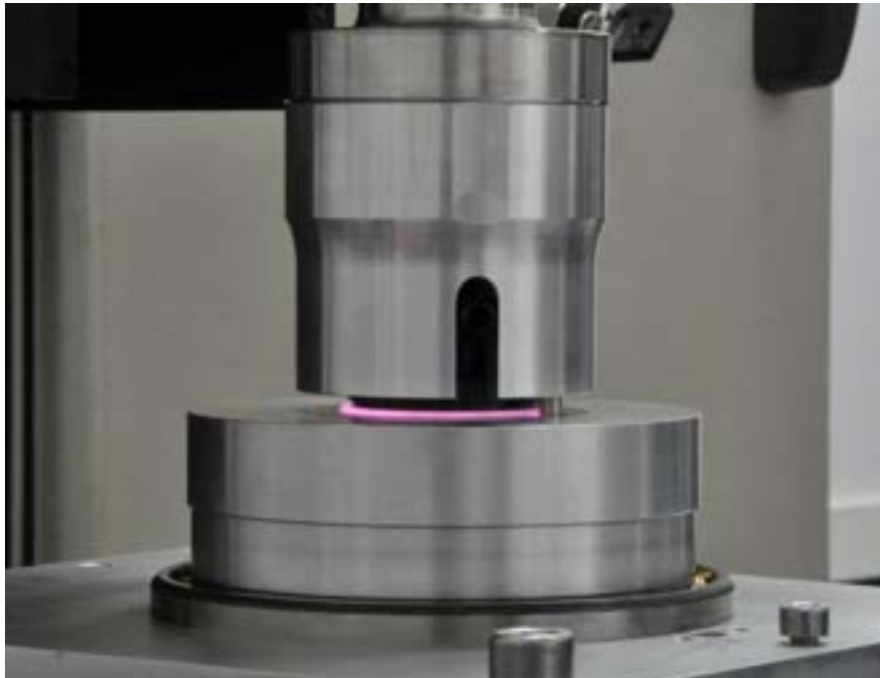

The laser welding is performed by the beam dissipation through the upper side of the part while the lower side of the part absorbs it to create the welding between both sides.

APPLICATIONS

Thermoplastic welding for small and medium parts (*Ex: dashboard, magnifying glass*)

ADVANTAGES

Process

- Compact tooling
- Reliable and strong process
- No alteration
- Repeatability +/- 0,02mm

Product

- No design restriction
- Aesthetic
- Strong mechanical resistance
- Waterproof
- Perfect control of the penetration distance

Materials the most commonly used : PC, PA, PP, PS, PEEK, PMMA, POM, PBT, TPU, PE

> MACHINE FEATURES

- Electrical driven press ramp up
- Upgraded and interchangeable generator
- Operator safety with light curtain
- Automatic recognition of the toolings
- Path programming (DXF)

> PROCESS FEATURES

- Laser Power up to 200W
- Traceability
- Repeatability
- Perfect control of the penetration distance



Notes :



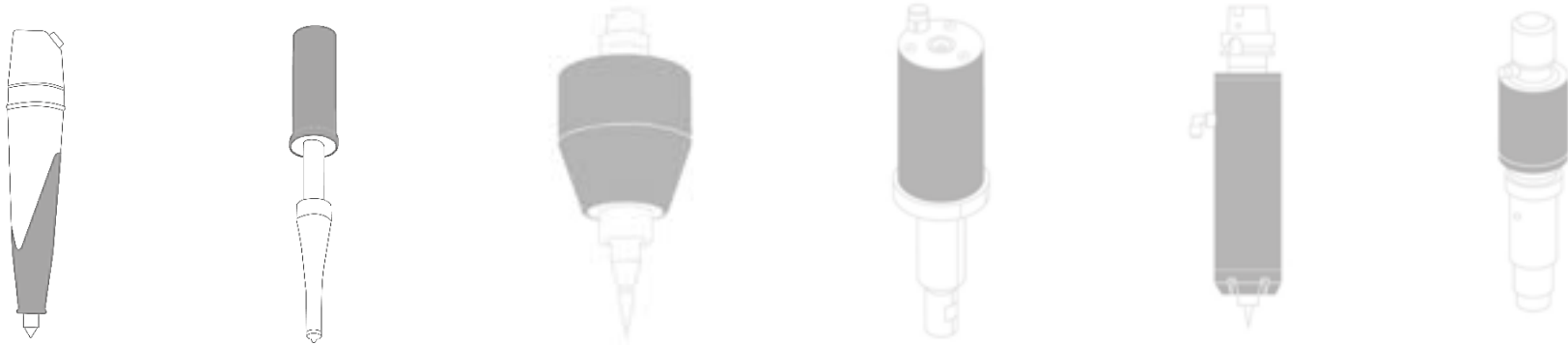

Portative and automated solutions for ultrasonic cutting and welding of composites materials



SONIMAT

Europe Technologies group

Our facilities

Welding and cutting: Composite - Food industry - Packaging - Non woven

SONIMAT

2 rue de la Fonderie

44470 CARQUEFOU - France

Phone : +33 (0)2 51 70 04 94

Welding Plastics - Automotive - Medical - Consumer Goods

SONIMAT

260 rue Santos Dumont

01200 VALSERHÔNE - France

Phone : +33 (0)4 74 73 40 79

Ultrasonic Processes

SONIMAT

27 rue Saint Exupéry - BP 50031

86140 LENCLOÎTRE - France

Phone : +33 (0)5 49 19 42 22

www.sonimat-et.com